



DH24

ELECTRONIC HUMIDITY CONTROLLER



Description

DH24 is an electronic hygrostat & dew point controller consisting of a connection box with the sensor for temperature and humidity (%RH) and a separate control panel with display. The controller is used when the control panel must be placed independent of the placing of the dehumidifier and the connection box. As an example, the connection box with the sensor is often placed close to the dehumidifier, and the control panel is placed more accessible ex. in a technical office. The control panel is connected to the connection box via an RS485 connection, and can be placed up to 500 meters away.

Application

The DH24 controller is designed for on/off control of Cotes dehumidifiers and can be used for all our dehumidifier models.

Controlling dew point and %RH makes it very suitable for water works and pump stations.

To eliminate condensation on cold surfaces as pumps and pipes the dew point must be kept below the surface temperature of the cold components.

But dew point alone allow for 100 %RH and for protection against mould and bacteria, the %RH must be kept below 70 %RH. Typical set points in a water work are dew point +8C, 70 %RH, which then will be the max values in the building.

For the dehumidification of crawl spaces under a family house, the dehumidifier and the connection box is placed in the crawl space, the control panel is placed at the ground floor in the house.

DH24 is also used as the controller for general dry air storage.

Electric connection and operation

Power supply 230V and hygrostat connection to the dehumidifier are connected to the connection box.

Between connection box and control panel, a thin RS485 connection must be made. Thus there are no 230V on the control panel.

Operation is only on the control panel. General status information of the control panel display is temperature, %RH and dew point.

It's in the air ...

... quality does indeed make a difference!



References
Waterworks
Dry air storage
Crawl spaces
etc.

DH24

ELECTRONIC HUMIDITY CONTROLLER

Technical data

- 207-253 V AC / 50 Hz supply
- Optional 24 V AC / 50 Hz supply
- 1 relay output 8 A / 230 V AC
- 1 relay output 16 A / 230 V AC
- 1 NTC input -30 - +70 °C / 0,1 °
- Integrated temperature sensor -40 - +60 ° / 0,1 °C
- Integrated humidity sensor 5-95 % RH / 0,1 % RH
- Accurate dew point calculation
- Real-time clock with lithium battery backup
- Accoustic signal for alarm
- Surrounding temperature -5 - +45 °C
- Humidity 5-95 % RH
- RS485 connection to control panel, max length 500 m.
- Tightness = IP54
- CE conformity. (EMC 89/336/EEC, LVD 73/23/EEC)
- B x H x D = 130 x 80 x 60 mm for main controller
- B x H x D = 75 x 75 x 30 mm for control panel.

Examples of applications

- Dehumidifier and humidifier on/off control
- Dew point control
- Alarm for dew point and %RH
- Waterworks, crawl space, dry air store etc

Connections

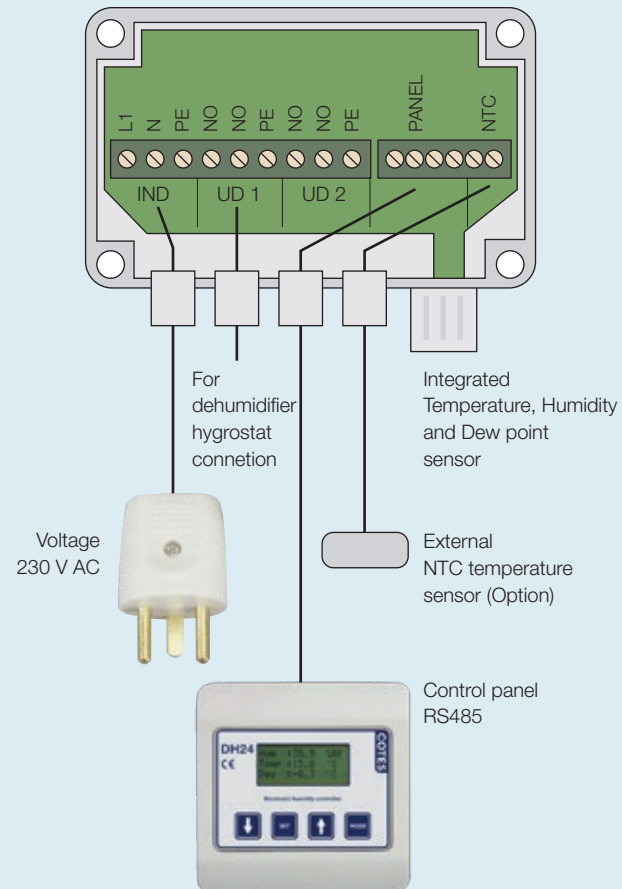

Distributor